

Ezy-Wash® Hob Mounted Pre-Rinse Unit Type 84H

Specification Data Sheet



Features

- ¼ turn jumper valve hot and cold control tap with 80mm levers.
- Stainless steel flexible hose connections with 1/2" BSP female connection on the inlets.
- 1000mm long high pressure hose with swivel ends.
- Stainless steel spring.
- Trigger hand spray.
- Bright chrome plate finish.

To Specify

Our range of Ezy-Wash® Pre-Rinse units are designed to clear excess food debris and sauces off dishes before placing them in commercial dish washing machines. Featuring an ergonomic trigger handle which allows easy and intuitive use. Our robust food service range complies with all relevant standards including AS/NZS 3718 and has been tested for cleanability to ASTM F2324-03 at 21.46 seconds. The heavy duty design makes it ideal for installation in all types of applications.

Code:

TF84HJS - Ezy-Wash® CP-BS Hob Mtd Twin Mixer Pre-Rinse Unit Type 84 Flex Tail - Std



A family
owned
Australian
business



Performance Standards & Approvals

- AS/NZS 3718 - WaterMark
- WELS 6 Star Rating



Typical Dimensions

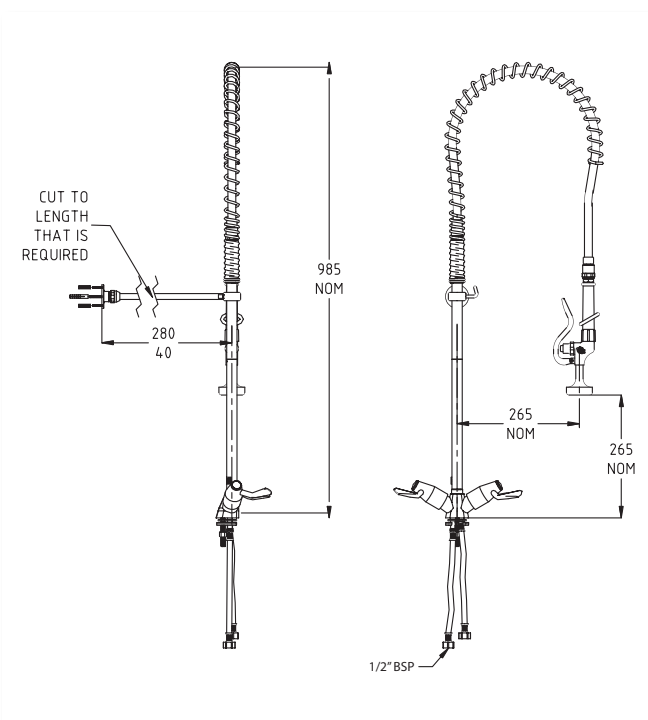

Technical Information

- Inlet: 1/2" BSP - Female Flexi Tails
- Outlet: Trigger Spray
- Headworks: Jumper Valve
- Working Pressure Range (kPa): 100 - 500
- Maximum Working Temperature (°C): 5 - 65
- Nominal Flow Rate: 3.5
- Construction: Brass
- Finish: Chrome

Maintenance & Cleaning

Galvin Engineering products should be cleaned with a soft damp cloth using only mild liquid detergent or soap and water. Do not use cleaning agents containing a corrosive acid, scouring agent or solvents. Do not use cream cleaners, as they are abrasive. Use of unsuitable cleaning agents may damage the surface. Any damage caused in this way will not be covered by warranty.

Regular maintenance should be carried out in accordance with the installation and troubleshooting guides provided with the product, relevant Australian Standards, local authorities and state codes.

As part of maintaining a safe and reliable plumbing system, we recommend tapware and valves are operated on at least a daily basis.

Warranty

Galvin Engineering products are covered under our Manufacturer's Warranty at www.galvinengineering.com.au. Galvin Engineering products must be installed in accordance with the installation instructions and in accordance with AS3500 and the PCA, relevant Australian Standards and local authorities applicable to product being installed. Water and electrical supply conditions must also comply to the applicable national and/or state standards, failing to comply with these provisions may void the product warranty and affect performance of the product.

Whilst all reasonable care has been taken in compiling the information in this document, the designs, dimensions and products shown are indicative only and should not be relied upon without our prior approval. Due to our policy of continuous development, we reserve the right to alter any details of specifications or products without notice. All information, drawings, technical specifications and product designs remains the property of Galvin Engineering Pty Ltd.

Within Australia: **1300 514 074** Outside Australia: P: +61 (0)8 9338 2344
 F: +61 (0)8 9338 2340
sales@galvinengineering.com.au
www.galvinengineering.com.au
 ABN: 78 008 719 382



PERTH | SYDNEY | MELBOURNE | BRISBANE | ADELAIDE | UNITED STATES OF AMERICA | UNITED KINGDOM | NEW ZEALAND